

# Application of Constrained Multi-objective Evolutionary Algorithm in Multi-Source Compressed-air Pipeline Optimization Problems

Yongkuan Yang\* Jianchang Liu\* Shubin Tan\* Honghai Wang\*

\* College of Information Science and Engineering, Northeastern University, Shenyang 110819  
PR China (e-mail: [yangyongkuan@mail.neu.edu.cn](mailto:yangyongkuan@mail.neu.edu.cn), [liujianchang@ise.neu.edu.cn](mailto:liujianchang@ise.neu.edu.cn),  
[tanshubin@ise.neu.edu.cn](mailto:tanshubin@ise.neu.edu.cn), [wanghonghai@ise.neu.edu.cn](mailto:wanghonghai@ise.neu.edu.cn)).

**Abstract:** To meet the request of manufacture, several compressor stations usually run at the same time. Decreasing the output pressure of compressor station is one of the major methods to reduce the power utilized by the motors of the compressors. Due to the interaction of several compressor stations with each other, how to set the output pressure of each compressor station becomes a big problem. This paper proposes the Constrained Multi-objective Optimization of Multi-Source Compressed-air Pipeline Optimization Problems (CMO-MSCPOPs) in compressed-air transmission networks of process industries. The problem formulation involves the minimization of the output pressure of each compressor station. Constraints associated with compressed-air flow rate and compressor stations guarantee the work of each downstream process. In case studies, the model is divided into two topology forms. The optimization of the model is performed using NSGA-II. The solution obtained is a set of Pareto solutions from which a decision making process is highlighted to select a specific preferred solution. Aiming to illustrate the performance of the proposed approach, the tool is applied to two typical network examples considering two compressor stations.

© 2018, IFAC (International Federation of Automatic Control) Hosting by Elsevier Ltd. All rights reserved.

**Keywords:** constrained multi-objective optimization, multi-source compressed-air supply, NSGA-II, multi-attribute decision-making, constrained-dominate relationship

## 1. INTRODUCTION

Compressed-air generation is energy intensive, and for most industrial operations, the fraction of energy cost in compressed air is significant compared with overall energy costs. Compressed air accounts for as much as 10% of industrial electricity consumption (Saidur et al., 2010). As compressed air flows through pipelines, pressure drops due to friction between the gas and the walls of the pipeline. In order to satisfy the need of utilities pressure, the output pressure of the compressor station usually keeps at a high level. Most of the time the pressure is overloaded, which causes a great deal of energy waste. Decreasing the output pressure of compressor station is one of the major methods to reduce the power utilized by the motors of the compressors (Durmus et al., 2002). To meet the need of manufacture, several compressor stations at different locations usually run at the same time, which composes the Multi-Source Compressed-air Pipeline System. How to set the output pressure of each compressor station with less energy consumption is an issue for industrial manufacture procedure.

Multi-Source Compressed-air Pipeline Optimization (MSCPO) belongs to the optimization of Pipeline Network. According to different time horizons, optimization of pipeline network is classified into single-period and multi-period. The single-period optimization considers information of one time interval (steady-state) and the multi-period optimization employs information from the future based on forecasting methods (Xenos et al., 2015). The steady-state pipeline

optimization examines the optimal operation of the fuel cost minimization problem (Wu et al., 2000). The multi-period pipeline optimization (considering solution for more than one time period) often considers a fixed number of operating compressors (Abbaspour et al., 2007). In this paper, we only focus on the steady-state pipeline optimization.

Constrained Multi-objective Optimization Problems (CMOPs) are difficult to address, especially for the non-linear optimization problems. Constrained Multi-objective Evolutionary Algorithms (CMOEA) have been successfully applied to a wide variety of optimization problems in the fields of science and engineering (Jan et al., 2010; Leong, 2008; Martinez et al., 2014). Few literatures are found dealing with multi-objective optimization of compressed-air pipelines. (Babonneau et al., 2012) formulated the operation and design of natural gas system as a bi-objective problem. They regarded minimizing the investment cost and energy cost as objective functions. Multi-Objective optimization of pipeline network usually considered two objectives: minimizing the transportation fare and the maximizing of the transported gas volume (Alves et al., 2016; Demissie et al., 2017). In our situation, the throughput is constant and equal to the actual demand of compressed air of utilities. Getting the transportation fare is hard in terms of establishing a precise mathematical model and the model parameter is often changed with maintenance and running time. Because the transport fare is proportional to the output pressure, we set each compressor-station's output pressure as the object to avoid the difficulty of establishing precise fare model.

In this paper, our main contribution is to address the multi-source compressed-air pipeline as a CMOP. According to the condition of actual application, we set each output pressure of compressor station as conflict objects and establish the steady state multi-objective optimization model. With application of Constrained Multi-objective Evolutionary Algorithm and multi-attribute decision-making, we find the optimal output pressure setting values of two compressor stations in two different typical network topologies. This tool will assist operators to make the most appropriate decision.

The rest of this paper is organized as follows: Section 2 presents the basic concept of the constrained multi-objective optimization problem; Section 3 establishes the model of Multi-Source compressed-air Supply system Optimization Problem; Section 4 presents the solver about the solution technique employed; Section 5 illustrates the utilization of the optimization scheme through its application to the pipeline network of two compressor-stations; Section 6 discusses the final conclusions.

## 2. BASIC CONCEPT

Without loss of generality, a nonlinear CMOP, which involves more than one conflicting objectives to be optimized simultaneously, can be formulated as follows (assuming minimization of all the objective functions):

$$\begin{aligned} \min F(x) &= [f_1(x) \quad f_2(x) \quad \cdots \quad f_l(x)] & (1) \\ \text{s.t.} \quad & \begin{cases} g_j(x) \leq 0, j = 1, 2, \dots, J, \\ h_k(x) = 0, k = 1, 2, \dots, K, x \in \Omega, \end{cases} \end{aligned}$$

where  $g_j(x) \leq 0$  and  $h_k(x) = 0$  represent the  $J$  inequality constraints and the  $K$  equality constraints,  $\Omega = \prod_{i=1}^n [a_i, b_i] \subseteq \mathbb{R}^n$  is the decision dimension,  $x = (x_1, \dots, x_n) \in \Omega$  is an  $n$  dimensional vector of decision variables. The objective vector function  $F$  consists of  $l$  real-valued objective functions.

In CMOPs, there is usually more than one constraint. In order to evaluate the constraints violation of a solution, an overall constraint violation is adopted which can be defined as follows:

$$\phi(x) = \sum_j \|\max\{0, g_j(x)\}\|^\alpha + \sum_k \|h_k(x)\|^\alpha \quad (2)$$

where  $\alpha$  is a positive number, i.e.  $\alpha \in (0, +\infty)$ . Equality constraints can be transformed into inequality constraints by using:

$$|h_k(x) - \varepsilon| \leq 0, k = 1, \dots, K \quad (3)$$

where  $\varepsilon$  is a small real-value threshold. A CMOP with equality constraints can be stated as one having only inequality constraints. Assuming that all constraints of problem (1) are inequality constraints, the constraint violation in (2) can be computed as:

$$\phi(x) = \sum_{j=1}^J \|\max\{0, g_j(x)\}\|^\alpha. \quad (4)$$

If  $\phi(x) = 0$ , the solution  $x$  is feasible. Otherwise, it is infeasible. Either of the two solutions  $x^1$  and  $x^2$  belongs to the feasible set  $S$ ,  $x^1$  is said to dominate  $x^2$  if  $f_i(x^1) \leq f_i(x^2)$  for each  $i = \{1, \dots, l\}$  and  $f_i(x^1) < f_i(x^2)$  for at least one  $i = \{1, \dots, l\}$ , denoted by  $x^1 \prec x^2$ . For a solution  $x^* \in S$ , we say that  $x^*$  is a *Pareto optimal* solution, if there is no other solution  $y \in S$  dominating  $x^*$ . The *Pareto optimal* set  $PS$  is defined as:  $PS = \{x \in \Omega \mid x \text{ is Pareto optimal solution}\}$ , and the *Pareto optimal front*  $PF$  is defined as:  $PF = \{F(x) \mid x \in PS\}$ .

## 3. OPTIMIZATION PROBLEM MODEL

### 3.1 System assumptions

Compressed air supply networks are complex transportation systems. In the modelling of these networks, we break the networks into nodes and pipelines to make simplifications. The network comprises of source nodes where compressor station provides compressed air into the supply system; demand nodes where gas flows in the utilities; intermediate nodes where the gas is rerouted. Pipeline segments are represented by arcs between two nodes. The following system assumptions are made:

**Identical compressors:** Compressor station consists of identical centrifugal compressors which are arranged in parallel in the source node. This type of compressor station is taken into account since it is common in today's compressed-air industry for its relatively low operation cost and maintenance. Its operation adopts constant pressure gas supply mode which could hold a stable pressure through its own control system.

**Constant flow direction:** Because the model is a steady state model, the flow direction of each pipeline segment in the network is known at steady state. We assume the flow direction is constant and the same as that of steady state.

### 3.2 Governing equations

The mathematical model to represent a steady state flow of gas in a network is developed based on characteristic coefficient of each pipe, pipeline flow equations and principles of conservation of mass.

**Characteristic coefficient of each pipeline:** The flow equation relates the gas flow rate with gas properties, pressure, pipe diameter and length. For a horizontal pipe, assuming temperature and compressibility factor stay constant at steady state, the flow equation can be calculated as:

$$Q_j^2 = k_{ij} (P_i^2 - P_j^2) \quad (5)$$

where  $k_{ij}$  is the characteristic coefficient of pipe  $ij$ , and is related to pipe diameter, pipe length, frictional factor, compressibility factor and so on.  $P_i$  is the pressure at the flow input node of pipe  $ij$ .  $P_j$  is the pressure at the flow output node of pipe  $ij$ . We get a set data of  $P_i, P_j, Q_j$  at different steady states, and a regression method (Rosipal and Krämer, 2006) is used to calculate  $k_{ij}$ . In the same way we can get the characteristic coefficient of each pipeline.

Continuity equation: The principle of continuity equation is derived from the fact that mass is always conserved in fluid systems regardless of the pipeline complexity or flow direction. For a steady state system, the flow rate does not change over time. The mass flow rate is calculated as:

$$m_{ij} = kP_jQ_j \quad (6)$$

where  $k$  is a conversion factor of constant value, for air its value is 0.0053.

Maximum allowable operational pressure: The basic requirement of a compressed air pipeline is to transport the compressed air safely and economically. A key safety requirement is the determination of a pipeline's maximum allowable operational pressure (MAOP) which is the highest pressure at which a pipeline can be operated, such that:

$$P_{ij} \leq MAOP_{ij}. \quad (7)$$

Minimum allowable operational pressure: The whole pipeline system need to satisfy the need of lowest pressure for the utilities normal use. So at each demand node there is a minimum allowable operational pressure (MIOP):

$$P_{D_i} \geq MIOP_{D_i}. \quad (8)$$

Flow balance equation at each node under steady state condition is shown as

$$\sum m_{in} = \sum m_{out}. \quad (9)$$

The  $m_{in}$  represents the mass flow of the pipeline which contains this node as a flow input node. Correspondingly, the  $m_{out}$  represents the mass flow of the pipeline which contains this node as a flow output node.

Because the number of running compressors does not change for a long time at each compressor station, we assume the value is constant in steady stage. The limit of mass flow of each compressor station is

$$(N_{Si} - 1)m_c < m_{Si} < N_{Si}m_c \quad (10)$$

where  $N_{Si}$  represents the number of compressor units operating within number  $i$  compressor station.  $m_c$  is the rated mass flow of a compressor.  $m_{Si}$  is the mass flow of compressor station  $i$ .

Objective functions: The objective functions are minimizing the output pressure of each compressor station:

$$\text{minimize } P_{S_1}, P_{S_2}, \dots, P_{S_i} \quad (11)$$

where  $P_{S_i}$  is the output pressure of number  $i$  compressor station.

Decision vector: The basic continuous decision variables are the pressure at each demand node  $P_{D_i}$ .

Limits of decision vector: The upper pressure limit for each decision vector is set to the value of MAOP. The lower pressure limit in each decision vector is set to the value of MIOP.

## 4. SOLVER

### 4.1 Multi-objective optimization algorithm

In the previous section, a CMOP was developed to minimize the output pressure of each compressor station. The model is non-linear and possesses conflicting objectives and highly complex search space. There are many meta-heuristics methods to solve CMOPs. Among these methods, evolutionary algorithms have gained popular attention due to their suitable nature for the application of multi-objective optimization of non-linear programming problems.

In this paper, the optimization of the model is performed using NSGA-II (non-dominated sorting genetic algorithm II) which is a multi-objective evolutionary algorithm that attempts to find *Pareto optimal* solutions. It uses the fast non-dominated sorting scheme and crowding distance estimation procedure for comparing qualities of different candidate solutions (Deb et al., 2002). Binary tournament selection is adopted as selection operator. When comparing two solutions  $i$  and  $j$ , if the two solutions exit constrained-dominate relationship, we choose the solution which constrained-dominate the other. Otherwise, we choose one by random. A solution  $i$  is said to constrained-dominate a solution  $j$ , if any of the following conditions is true:

- 1) Solution  $i$  is feasible and solution  $j$  is not.
- 2) Solutions  $i$  and  $j$  are both infeasible, but solution  $i$  has a smaller overall constraint violation degree.
- 3) Solutions  $i$  and  $j$  are feasible and solution  $i$  dominates solution  $j$ .

### 4.2 Multi-attribute decision-making

The solution by multi-objective optimization algorithm is *PS* which has a set of *Pareto optimal* solution. Generally, every *Pareto optimal* solution is an acceptable solution. In actual production, only one plan is used to guide the production. A decision-maker has to choose a single solution from the *PS*. We carry on the multiple attribute decision-making according

to the weight satisfaction of the solution. First of all, we remove the solution governed by steady state from the *PS*. We use the fuzzy membership functions to describe the weight satisfaction degree of each objective function in each of the rest *PS*. Equation (12) is a function describing the weight satisfaction degree of fuzzy membership:

$$u_i = \lambda_i \frac{f_{i,max} - f_i}{f_{i,max} - f_{i,min}} \quad (12)$$

where  $f_i$  is the  $i$ th objective function value of *Pareto optimal* solution.  $f_{i,max}$  represents the  $i$ th objective function maximum value of the *PS* whereas  $f_{i,min}$  represents the  $i$ th objective function minimum value of the *PS*. The  $\lambda_i$  is a weight vector, i.e.,  $\forall i = 1, \dots, m$  and  $\sum_{i=1}^m \lambda_i = 1$ . The weight vector  $\lambda_i$  is related to the operation load of each compressor station and can be calculated as:

$$\lambda_i = \frac{N_{Si}}{\sum_{i=1}^m N_{Si}} \quad (13)$$

For each *Pareto optimal* solution, we calculate the sum of satisfaction degree of the objective functions and the largest is the best solution. Finally, we set the objective value of the best solution to guide the production.

### 5. CASE STUDIES

Double source pipeline network is common in Multi-Source compressed-air Supply system. The double source pipeline network with different topology is chosen as our case study.

#### 5.1 Case in two different network topologies

According to the network topology, double source pipeline network can be divided into two forms: tree topology and looped topology. The looped topology is complex to tree topology and is difficult to solve. Both of them can include many demand nodes. For a representative sample, we set four demand nodes on each form. The model structure is also applied to the demand node of network more or less than four by adding or decreasing the demand node to the network topology and establish the model in the same way.

Tree topology in case 1: This type of network topology has a main pipeline connecting the two source compressor stations. A large number of demand nodes are scattered on the main pipeline. The typical tree topology is shown in Figure 1.

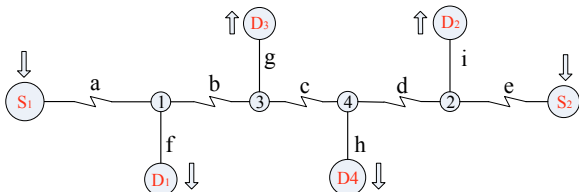

Fig.1. Typical tree topology.

There are two source nodes  $S_1$  and  $S_2$  on behalf of two compressor stations. The demand nodes are  $D_1, D_2, D_3,$  and  $D_4$ . The network has nine pipelines from a to i and four media nodes from 1 to 4. The characteristic coefficient of each pipeline from pipeline a to pipeline e is 301.3519 whereas that of the others is 232.1117.

At the current stable state, the state of pipeline network is described in Table 1 and Table 2.

Table 1. The pressure at source and demand node.

node	$S_1$	$D_1$	$D_2$	$D_3$	$D_4$	$S_2$
$P(\times 10^2 \text{psia})$	7.10	6.27	5.90	5.19	5.16	6.55

Table 2. The mass flow at source and demand pipeline.

node	$S_1$	$D_1$	$D_2$	$D_3$	$D_4$	$S_2$
$m(\times 10^5 \text{scf/M})$	3.32	1.06	1.06	1.66	1.66	2.12

The MAOP at each demand node is set to 800 psia. The MIOP at each demand node is set to 500 psia.  $N_{S1}$  representing the number of running compressors in compressor station  $S_1$  is 5.  $N_{S2}$  representing the number of running compressors in compressor station  $S_2$  is also 5. The rated gas production of compressor named as  $m_c$  is equal to 5000 scf/M.

Looped topology in case 2: The other topology for compressed air transportation system with two source compressor stations is looped network. The typical looped topology is shown in Figure 2.

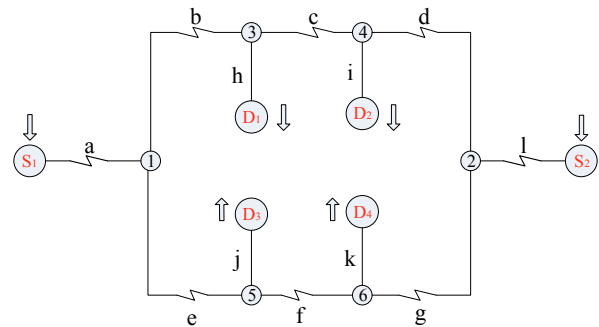

Fig.2. Typical looped topology

The number of source and demand nodes is the same to case 1. The network has twelve pipelines from a to l and six media nodes from 1 to 6. The characteristic coefficient of each pipeline from pipeline a to pipeline i is 301.3519 whereas that of the others is 232.1117. At the current stable state, the state of pipeline network is described in Table 3 and Table 4.

Table 3. The pressure at source and demand node.

node	$S_1$	$D_1$	$D_2$	$D_3$	$D_4$	$S_2$
$P(\times 10^2 \text{psia})$	6.83	5.98	5.98	5.35	5.35	6.90

Table 4. The mass flow at source and demand pipeline.

node	$S_1$	$D_1$	$D_2$	$D_3$	$D_4$	$S_2$
$m(\times 10^5 \text{scf/M})$	3.32	1.06	1.06	1.66	1.66	2.12

The set of MAOP and MIOP at each demand node is the same as case 1. The number of running compressors in compressor station and the rated gas production of compressor are also the same as case 1.

### 5.2 Two objective functions of each case

Minimize the output pressure of compressor station 1:

$$\text{minimize } P_{S_1} = \sqrt{Q_{S_1}^2 / k_{S_1} + P_1^2} \quad (14)$$

where  $k_{S_1}$  is the characteristic coefficient of pipe  $S_1$ .

Minimize the output pressure of compressor station 2:

$$\text{minimize } P_{S_2} = \sqrt{Q_{S_2}^2 / k_{S_2} + P_2^2} \quad (15)$$

Where  $k_{S_2}$  is the characteristic coefficient of pipe  $S_2$ .

### 5.3 Result and discussion

In the implementation of NSGA-II, a population size of 100 is considered. The probability of the crossover is 0.9 and the probability of the mutation is 0.8. We use real-coded GAs with the simulated binary crossover (SBX) operator and polynomial mutation. The distribution indexes for crossover and mutation operators are  $\eta_c = 20$  and  $\eta_m = 20$ , respectively. The algorithm runs 15 times independently for each case. The maximum number of objective function evaluation allowed is set to 120,000.

Case 1 which is a tree topology includes 4 decision variables and 12 constraints to optimize the objective functions. The optimization problem is solved and the *Pareto optimal* points of best run are presented in Figure 3. Using a computer with Intel Core(TM) i3-2120 3.30 GHz model and 3 GB RAM, the CPU computation time for this case is averaged as 5530 ms.

Case 2 which is a looped topology has 4 decision variables and 14 constraints to optimize the objective functions. The optimization problem is solved and the *Pareto optimal* points in the best run are presented in Figure 4. Using the same computer as case 1, the CPU computation time for this case is averaged as 6556.5 ms.

After multi-attribute decision-making using the method of section (4.2), the best output pressure set of two compressor stations is showed at table 5.

Table 5. The comparison of the output pressure set.

optimization	Case 1		Case 2	
	$P_{S_1}$	$P_{S_2}$	$P_{S_1}$	$P_{S_2}$
Before	709.05	655.28	682.78	689.26
After	707.18	644.49	663.72	681.56
decline	1.87	10.79	19.06	7.7

In case 1, the output pressures of two compressor stations are set to 707.18 psia and 644.49 psia, which decline 1.87 psia and 10.79 psia respectively compared to previous

optimization. In case 2, the output pressures of two compressor stations are set to 663.72 psia and 681.56 psia, which decline 19.06 psia and 7.7 psia respectively compared to previous optimization.

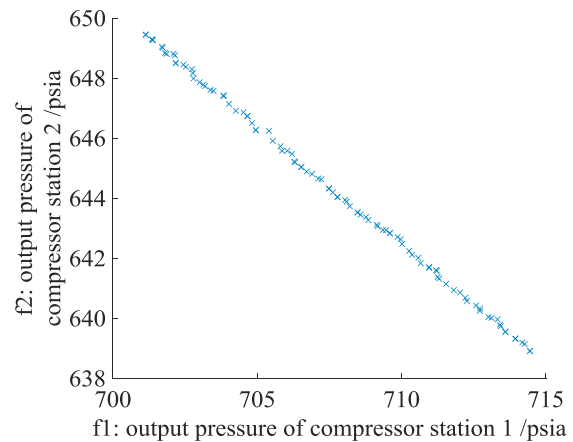

Fig.3. Optimum points at best run time for linear topology in case 1.

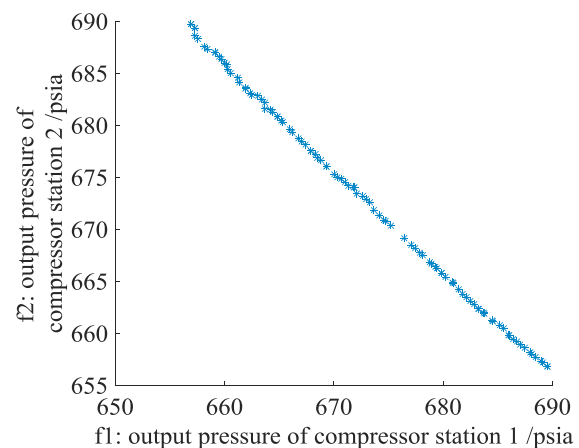

Fig.4. Optimum points at best run time for looped topology in case 2.

### 5.1 Consistency analysis of solution

To analyse the consistency of solutions, we run each case 5 times with all the other parameters unchanged. Figure 5 shows the results of *Pareto optimal* front *PF* in case 1 at each running time. The *Pareto optimal* front *PF* of case 2 after running each time is shown in Figure 6.

Just like most of reality application MOPs, we do not know the global *PF* in our problem. The solutions can only be as close as possible to the global *PF*. As shown in Figure 5, the results of running 5 times show every time the solution converges to the same *PF*. But in case 2 with a more complicated constraint than case 1, the result is different. As shown in Figure 6 nearly every time the solution converges to local *PF*. This is because binary tournament selection based on constrained-dominate relationship is difficult to play the role of infeasible solution. When most of the individuals in the group are feasible solution, the infeasible solution is difficult to access.



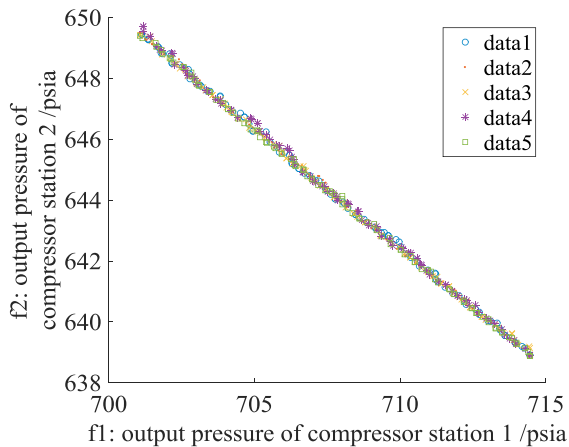

Fig.5. The result of case 1 running 5 times.



Fig.6. The result of case 2 running 5 times.

## 6. CONCLUSIONS

This paper established a multi-objective optimization model for multi-source compressed air transmission network. The developed model was applied to tree and looped topologies. The goal was to find optimal operating condition for any network. The objectives considered are minimizing each output pressure of compressor stations subjected to pressure and mass flow constraints in pipeline and compressor station. The case studies represent the two topologies existing in the real world system. They lay the foundation for investigating large and complex networks which are the combination of these two typical topologies of multi-source compressed air supply system. The solution of the multi-objective model is a set of non-dominated front solution points which is a trade-off curve between different objectives. A final solution is chosen by the multiple attribute decision-making according to the weight satisfaction of the solution and the objective value of final solution is used to guide the production. This article presents a method of solving multi-Source Compressed-air Pipeline Optimization Problems at the steady state.

## REFERENCES

- Abbaspour, M., Krishnaswami, P., & Chapman, K. S. (2007). Transient optimization in natural gas compressor stations for linepack operation. *J Energ Resour-Asme*, 129(4), 314-324.
- Alves, F. D. S., Souza, J. N. M. D., & Costa, A. L. H. (2016). Multi-objective design optimization of natural gas transmission networks. *Comput Chem Eng*, 93, 212-220.
- Babonneau, F., Nesterov, Y., & Vial, J. P. (2012). Design and operations of gas transmission networks. *J Oper Res Soc*, 60 (1), 34–47.
- Deb, K., Pratap, A., Agarwal, S., & Meyarivan, T. (2002). A fast and elitist multiobjective genetic algorithm: NSGA-II. *Ieee T Evolut Compu*, 6(2), 182-197.
- Demissie, A., Zhu, W., & Belachew, C. T. (2017). A multi-objective optimization model for gas pipeline operations. *Comput Chem Eng*, 100, 94-103.
- Durmus, K., Patrick, P., David, C., & Ibrahim, S. H. (2002). Energy conservation in compressed-air systems. *Int J Energy Res*, 26(9), 837–849.
- Jan, M. A., & Zhang, Q. (2010). MOEA/D for constrained multiobjective optimization: Some preliminary experimental results. *Comput Intell*, 1-6. IEEE.
- Leong, W.F. (2008). Multiobjective particle swarm optimization: integration of dynamic population and multiple-swarm concepts and constraint handling. *Dissertations & Theses - Gradworks*.
- Martinez, S. Z., Montano, A. A., & Coello, C. A. C. (2014). *Constrained multi-objective aerodynamic shape optimization via swarm intelligence*, 81-88. ACM.
- Rosipal, R., & Krämer, N. (2006). Overview and recent advances in partial least squares. *Lecture notes in computer science*, 3940, 34-51. Berlin, Germany: Springer-Verlag.
- Saidur, R., Rahim, N. A., & Hasanuzzaman, M. (2010). A review on compressed-air energy use and energy savings. *Renew Sust Energy Rev*, 14(4), 1135-1153.
- Wu, S., Os-Mercado, R. Z., Boyd, E. A., & Scott, L. R. (2000). Model relaxations for the fuel cost minimization of steady-state gas pipeline networks. *Math Comput Model*, 31(2–3), 197-220.
- Xenos, D. P., Ciccotti, M., Kopanos, G. M., Bouaswaig, A. E. F., Kahrs, O., & Martinez-Botas, R., et al. (2015). Optimization of a network of compressors in parallel: real time optimization (rto) of compressors in chemical plants – an industrial case study. *Appl Energy*, 144(5), 51-63.